

Rail Guard MPPT Solar Power Unit – User Manual

Model: RGSPU-12.8V-50A-110V-1.5A

The Rail Guard MPPT Solar Power Unit is a compact, high-efficiency, solar-powered solution specifically engineered to meet the continuous power requirements of a railway guard van. The system integrates an MPPT solar charge controller for a 12.8 V LiFePO₄ battery and a regulated 12.8 V to 110 V DC DC–DC converter in a single enclosure. It provides reliable power to lights and fans in the van without the need to connect to mains AC power or rely on regular movement with trains.

The unit is powered by a 550 Wp solar panel (maximum 750 Wp) mounted on the roof of the railway van. This panel charges a 12.8 V, 120 Ah LiFePO₄ battery using a smart MPPT solar charge controller under varying solar irradiance conditions. The maximum charging current is 50 A. Bulk and trickle charging modes are implemented to ensure long battery life.

Installation Procedure

1. Install the RGSPU unit in the battery cabinet.
2. Connect the battery with correct polarity. The display should turn on.
3. Ensure that the solar panel array voltage is below 85 V.
4. Connect the solar panel with correct polarity.
5. Charging will start automatically during daytime.
6. Check the output for Solar panel voltage, current; Battery voltage and current; Output voltage and current. Check that 110V output is present at the output
7. Connect load at the output and check that it is functioning normally.
8. Front panel key function:
 - a) Display back light is turned off after 5 minutes of inactivity. Press this key once to turn on the back light.
 - b) If this key is pressed two times in quick succession, Energy meter readings are displayed.
 - c) If this key is pressed three times in quick succession, It asks whether the user wants to reset the energy meter. If the user presses the again three times in quick succession, the energy meter is reset.

- d) If this key is kept pressed for longer than 1.2 seconds, it asks whether the user wants to restart the system. If this key is again pressed for more than 1.2 seconds, the system restarts. This feature may be useful in the unlikely event of the a stuck fault condition.

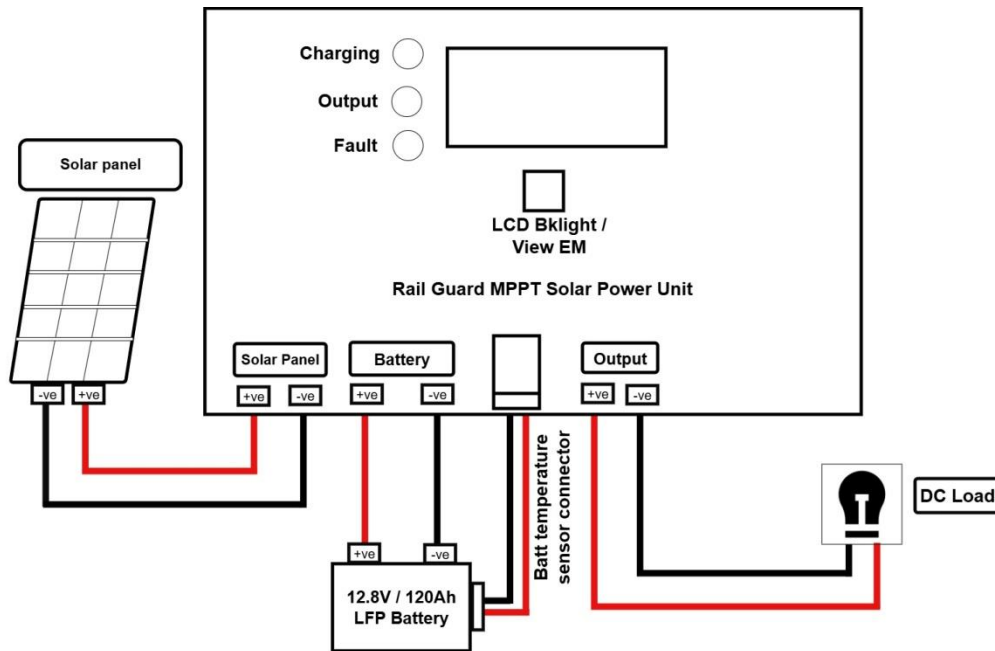

File: Rail Guard MPPT Solar Power Unit Connection Block diagram

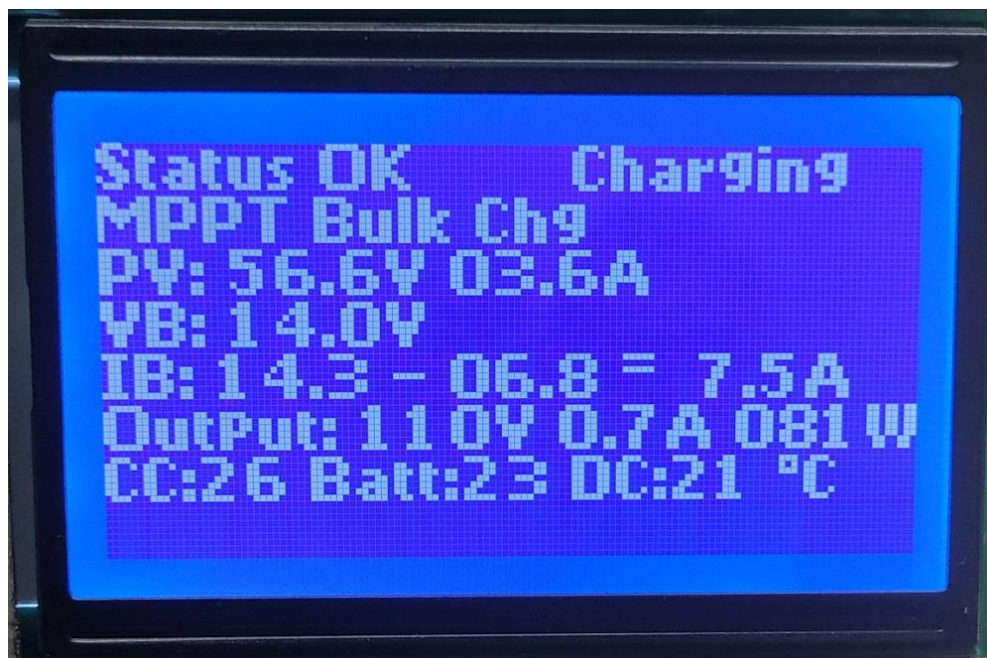

LCD Display

Technical specifications

S No	Item	Description
1.	Battery	12.8V 120AH LiFePO4. Recommended connection wires: 10 mm sq.
2.	Solar panel maximum V _{oc} (open circuit solar panel voltage)	85V
4.	Solar panel maximum allowed capacity	750Wp. Recommended connection wires: 4 mm sq.
5	Load output	110V DC 1.5A. Recommended connection wires: 1.5 mm sq.
6	Display:	128x64 pixel back-lit graphic display which can display 8 rows of about 22 characters each for display of running parameters during operation and the Energy meter values
7	Keyboard	1 Key Single press: LCD back light on Double presses quickly: Display energy meter values Three presses quickly: Option to reset energy meter Long press: System restart
8	LED indicator Green	Charger status: <ul style="list-style-type: none"> • Off: Not charging • 1 Blink every 2sec: <ul style="list-style-type: none"> ➤ Low charging (< 5A) • 2 Blinks every 2sec <ul style="list-style-type: none"> ➤ High charging (>= 5A) • Solid ON: Battery fully charged

9	LED indicator Blue	<p>DC-DC converter status:</p> <ul style="list-style-type: none"> • Solid On: Normal output • 1 Blink every 2 seconds: Output overload • 2 Blinks every 2 seconds: DC-DC converter heat sink temperature high (above 70 deg C) / Temperature sensor disconnected. • 3 Blinks every 2 seconds: Output voltage too high shutoff <p>DCDC converter is shutoff for all the above faults. It restarts automatically when the fault is removed.</p>
10	LED indicator Red	<p>Charge controller status:</p> <ul style="list-style-type: none"> • Off: Normal operation • 1 Blink every 2sec: <ul style="list-style-type: none"> ➤ Battery discharged (Battery voltage below 12.0V). (Charging continues, Load is off). Once the battery voltage rises above 12.8 V, this fault is reset and the output starts coming. • 2 Blinks every 2sec: <ul style="list-style-type: none"> ➤ Solar charger heat sink temperature high (Above 70 deg C) / Temperature sensor disconnected. Charging Stop • 3 Blinks every 2sec: <ul style="list-style-type: none"> ➤ Solar panel voltage too high. Charging is stopped. • Solid on: Battery voltage too high
11	2-stage charging for maximum battery care:	<ol style="list-style-type: none"> 1. Bulk charging mode, till the battery voltage reaches about 14.5V. 2. Trickle charging mode at 13.6 V. Charging mode is changed to Bulk charging mode if battery voltage goes below 13.0V.

12	Temperature compensation of charging thresholds	Temperature sensor for battery is provided and the battery temperature is displayed on LCD. However, for LiFePO4, no temperature compensation is recommended by the manufacturer. If this temperature increases above 50 deg C, there is some problem in the battery which should be attended to.
13	Protections	<ul style="list-style-type: none"> ● Battery reverse polarity ● Solar panel reverse polarity ● Output overload ● Output short circuit ● Charge controller overheat ● DC-DC converter overheat
14	Idle power	By battery charger: Max1.3 W. By DC-DC converter: Max 12W.
15	Charge Controller Efficiency	>95%
16	DC-DC Converter Efficiency	>90%
17	Technology	<p>Solar charger: Two Interleaved Synchronous Buck Converter channels.</p> <p>DC-DC converter: Transformer based forward converter</p>
18	Microcontroller controller	ARM M4 core based 32-bit advanced microcontroller

* For continuous product improvement, product specifications can change without notice.

Company Contact details:

Systemlar Innovations

Shankar Chowk, Delhi Road, Meerut – 250002

Ph: 0121-434 2043 Email: info@systemlar.in